

# A Review on Design and Control of AGC and AVR for Multi-Area Interconnected Power system

**Mr. Abdulkerim Ali**

Faculty of Electrical and Computer Engineering  
Bahir Dar Institute of Technology  
Bahir Dar, Ethiopia  
[abduali548@gmail.com](mailto:abduali548@gmail.com)

**Dr-Ing. Belachew Bantyriga**

Faculty of Electrical and Computer Engineering  
Bahir Dar Institute of Technology  
Bahir Dar, Ethiopia  
[belachewb@yahoo.com](mailto:belachewb@yahoo.com)

**Dr-Ing. Getachew Biru**

School of Electrical and Computer Engineering  
Addis Ababa Institute of Technology  
Addis Ababa, Ethiopia  
[gbiru@yahoo.co.uk](mailto:gbiru@yahoo.co.uk)

**Abstract:** There are a variety of controls available for analyzing and learning power systems, it is important to develop a balanced view of controls in terms of a number of conditions, such as: balancing power between production and demand, balancing effective power between production and customers. This paper presents a review and comparison of the tools used to control the most widely used energy systems for analyzing energy and electricity systems. It reviews available literature and follows a systematic approach to distinguishing other controls and models that can serve as a guide for selecting the most appropriate old and modern control system, keeping frequency and power within the permissible limit and improving the operating system features.

**Keywords:** Frequency response, Voltage response, AGC, AVR

## 1. Introduction

Currently, more than 17% of the electricity generated in water in the name comes from the hydropower system and that is connected. The energy system usually consists of a multi-component energy system with domestic, industrial and commercial loads. In order to operate efficiently and to control the power system, these loads need constant operation and voltage with reliable, sufficient & efficient power [Saifi et al, 2015]. If it suddenly increases the load, the potential internal or external disruption that occurs in the generation or transmission system will be fluctuate the entire system which means it will have an error of frequency, power, and voltage from the normal system value [Elgerd et al, 2008]. Therefore, the system must be required a stable or

stability or rotor angle stability and the other is voltage stability. Angular stability is generator stability while voltage stability means load stability. The rotation angle of the rotor is closely linked to the actual power transmission while the voltage stability is related to reactive power [Yarlagadda et al, 2015]. Each of these issues can be categorized into major or minor disruptions, short-term or long-term [Kundur et al, 1994]. Serious problems in one area, as well as a large interconnected power system, load change, sudden increase in input power, disruption, etc. Those have been the instability of the power system. That means the system frequency and voltage will have changed. Changes in power system loading primarily affect system frequency, operating power, and the power of the connected power system or power line, while major disturbances or errors such as a three-phase error affect system voltage and operating power [Nath et al., 2015].

The power system must be maintained at the desired level of operation characterized by nominal frequencies, power profile and load flow planning. It is maintained in this normal state by the close control of real and active power generated from the system's controlling sources. Production changes should be made to match the load variability in normal conditions if the self-reported condition is maintained. In order to gain high active energy, reactive energy must be compensated. This compensation is needed to improve the stability of the power supply control system. An increase in the operating capacity of the generator is accompanied by an increase in the decrease in the amount of

electrical energy. The main voltage generator terminal methods and power control at a certain level control the generator excitation using AVR [Abdulkerim et al, 2019]. The imbalance between productivity and demand causes the system and the power supply to be constantly leaked or normal. When the load on the system is increased, there is a decrease in frequency because the governor speed decreases. AGC is therefore a system that restores frequency and tie line power to its nominal value automatically [Sambariya et al, 2016]. The main objective of the AGC is to measure system productivity against systemic load and loss so that the desired frequency, operating power, and exchange capacity of neighboring systems are maintained [Dabur et al., 2011].

In this paper, we review the available manuals for the design and control of power systems connected in multiple locations using AGC and AVR with a robust and modern multidirectional control (FLC) controller to improve or enhance the flexible operating features of the system. It is also responsible for the combination of automatic generation control (AGC) and automatic voltage control (AVR) to measure system output volume against system load and loss, terminal voltage capture, frequency, operating power, operating power, and tie-line system capacity of forces connected in multiple locations at a specified level, to weaken the oscillation response system. Also, the correlation between frequency deviation and voltage deviation is analyzed in this paper and modeled on Matlab / Simulink.

## 2. Power System Controls

### 2.1 Classification of controllers

The main purpose of the operation and control of the power system is to maintain a continuous supply of energy with the right quality, for all customers in the system. The system will be balanced if there is a balance between the demand for energy and the energy produced [Venu et al, 2015]. Power system controls can be broken down using a few conditions. A wide variety of literature has developed different ways to differentiate the performance and control of the energy system. [Sambariya et al, 2015; Omveer et al, 2013; Dabur et al, 2012; Singh et al, 2011] identified three key objectives for regulating the energy system. This balances the actual power between generations and demand, balancing the

active power between generation and load, maintaining the flow of power of the tie line. Similarly, with the balance between active power generation and demand, the electric power profile is also maintained within the set limits. [Avtar et al, 2012] discussed two conditions for distinguishing different types of control system power system namely power control and frequency control. [kundu et al,] described the various controls for the development of the electrical profile. These are generators and load tripping, dynamic braking resistor, high voltage DC, fast excitation (AVR). [Kumar et al, 2011] discussed the different components of power control which are transformer load pump switches, capacitor switches, power controls, and stationary var control devices. But they are not fast and reliable. [Kiran et al,] introduced different ways to control electrical energy in the energy system as follows: tap transformers, input controller, shunt reactors, shunt capacitors and synchronous condensers, STATCOM and Excitation control (AVR).

The actual power in the power system is controlled by controlling the torque of the individual turbines of the system. We have different controls of frequency and energy (real) power systems. These are Flexible AC transmission system (FACTS), load frequency control (LFC), automatic generation control (AGC) In order to improve the stability of the power system must be controlled by the generator of the electric power and operating power as well as the frequency and operating power within the set limits. Under continuous conditions, the amount of actual power generation in the system is equal to the total MW demand and real power loss.

With this in mind, we have come up with an extensive and comprehensive section that is important to this study in terms of comparisons of electrical and energy controls and actual frequency and actual power. The method of controlling the voltage and power is as follows: Tap transformer, FACTS, synchronous compensation, and AVR. And the method to control the frequency and real powers are FACTS, LFC, and AGC. Each of these control measures to improve and control the performance of the power system is discussed in detail below.

## 2.2 Voltage and Reactive Power Control

The production of active energy and the absorption of the energy system are important as active energy is very important in keeping the voltage of the energy system stable. The main components of the production and absorption of active energy are transmission cables, transformers, and alternators. The voltage of the power system may vary with load change. The voltage is usually higher when loaded and low in the case of a heavy load. In order to keep the system voltage at limits, some additional equipment requires increasing the system voltage when it is low and lowering the voltage when it is too high [Prakasam et al, 2013]. The following are the methods used in the power system to control voltage and active power.

### *Tap changing transformer*

*Off-Load Tap Changing Transformer:* - In this method, the voltage is controlled by changing the turning rate of the transformer. The transformer is disconnected from the supply before replacing the tap. Changing the transformer tap is usually done by hand.

*On-Load Tap Changing Transformer:-* This system is used to convert the transformer turning rate to control the electrical power of the system when the transformer delivers the load. Most power transformer is supplied with a charging tap switch.

### *Synchronous compensator*

The synchronous phase modifier is the synchronous motor running without a mechanical load. The synchronized phase converter absorbs or produces active energy by exchanging the interest of the curves of the field. It keeps the voltage constant at any load condition and improves the power factor.

### **FACTS**

The main objectives of FACT are: To improve the control of the power supply and the power factor, to increase the transmission capacity, to increase system stability, to reduce system losses in the transmission system. FACTS controls are able to control power very quickly. The Thyristor control series compensator (TCSC) helps control the current line in the transmission line and enhances system stability [Kajal et al, 2019]. Based on the purpose we have two types of FACT which is shunt compensation and series compensation. FACTS concepts are based on

the use of electrical energy technology in an existing ac transmission system; this improves stability to achieve energy transfer near its temperature limit [Chaturvedi et al, 2013].

**Shunt compensation:** - These controls apply current to the system in the connection area. When this current is in phase quadrature and line voltage, the shunt controller uses or provides flexible operating power in the network. These controls can be a flexible reactor or a capacitor or a flexible source-based electronics. A capacitive compensator generates an electric field thus generating effective energy. The inductive compound produces a magnetic field that absorbs active energy. Maintains and controls the parameters (usually the bus voltage) of the power system. Capacitors produce var and may be connected to a series or shunt in the system. Shunt capacitors are used for active compensation. Examples of shunt controls include TCR, STATCOM, TSR, TSC, and static var compensator (SVC) - Voltage source converter.

[Mahinda et al, 2010] discussed Boost PWM power source generators that have gained popularity because they allow the output voltage to be controlled over a wide range. [Sreerama et al, 2013] introduced Static VAR Compensator (SVC) is one of the shunts connected to FACTS devices, which can be used to compensate for the active power of transmission lines. [Suryakalavathi et al, 2013] attempts to design and emulate Fuzzy's intelligent control of SVC's shooting angle to achieve better, smoother, more flexible controls. But the limit of this control did not take into account the frequency, the active force, the power of the tie line.

**Series compensation:** - Here capacitors are connected in series by line. The main objective is to reduce the inductive reaction between the supply area and the load in order to improve the stability limit. However, they cause additional problems such as high voltage, sub-synchronous resonance, etc. The main disadvantage of the method whenever the curcy of the short circuit flows into the capacitor, protective devices such as spark plugs and nonlinear resistant materials should be installed.

### **Automatic Voltage Control (AVR)**

A power control system is also called an excitation control system or automatic voltage control (AVR). Depending on how the dc supply is delivered in the

alternator (rotor) threat area, exciters are classified as DC Exciters, AC Exciters, and Static Exciters. The main purpose of AVR is to control the terminal voltage and the magnitude of the active power of the synchronous generator at a specified level [Dabur et al, 2011]. [Donde et al, 2001] stated that an increase in the operating capacity of a generator is accompanied by a decrease in the magnitude of the electric field.

### **2.3 Frequency and Real Power Control**

**Series compensation:** In this case, various compensation or FACTS devices (which can be changed or controlled) are connected to a series of transmission cables in specific locations. This compensation will provide more control over the flow of energy along the line and improve the flexible stability of the power system. Thyristor-controlled switched capacitor (TCSC) and capacitor series (FSC) techniques are widely used in series compensation. Therefore, Thyristor controlled series capacitance (TCSC) is used to maximize the effective active transmission line power. [Choi et al, 2010] investigated the use of super-capacitor as a energy-saving device in plants that generate renewable energy to improve energy transfer. Energy from renewable sources such as wind, solar or tidal is unstable and as a result, its impact on the quality of network feeds can be a major problem.

**Load frequency control (LFC):** To understand how to control the frequency, consider the small step-up of the load. The initial distribution of load increases is determined by the system impedance; and the relative positions of the relative immediately. The power required to provide the load increase is derived from the kinetic energy of rotating machinery. As a result, system frequency decreases. The main objective of the LFC is to achieve the ultimate goal of real power balance by adjusting the turbine outlet to match the change in load requirement due to the reduction of system deviation. [Vivek et al, 2016] introduced Load Frequency Control using an Incomprehensible Multimedia-based Power Management System to maintain a systematic frequency and power exchange with other locations at specified limits. However, the paper did not control the voltage and operating power and did not remove the error of the solid and temporary position.

The purpose of the load frequency control (LFC) is to maintain a fixed frequency and fixed line power in the normal operating mode, during minimal disruption in operating conditions. Maintain the need for a local generator at a fixed limit by adjusting the output of the ruler [Usman et al, 2012; Yesil et al, 2004]. [Kavita et al, 2017] introduced the complete tuning of the PID controller in both the Load Frequency Control (LFC) and the Automatic Voltage Regulator (AVR) for two connected power system components to control the frequency and power of the system.

**Automatic generation control (AGC):** The ALFC is to control the deviation of frequency by maintaining a real power balance in the system. The main functions of the ALFC are to i) maintain a constant frequency; ii) regulate the flow of binding lines, and iii) distribute the load between participating production units. Signal controls (input)  $\Delta P_{tie}$  line deviation (measured by line curve), and frequency  $\Delta f$  (obtained by measuring angle deviation  $\Delta \delta$ ). The strongest error will be eliminated by the AGC compared to the LFC.

Therefore, we understand from the various literature reviews, to keep the active and efficient power in the transmission system used by the FACTS controller and there are two basic and fast control methods in the power system generator used to maintain the active power balance (acceptable voltage profile) controlled by AVR and real power balance (acceptable frequency values) are AGCs in a fixed, flexible or temporary environment.

## **3. Design and Modeling of Controller**

### **3.1 Automatic Voltage Regulator**

Voltage stability is the ability of an acceptable energy storage system to remain unchanged on all buses in the system under normal operating conditions and after a breakdown, increased load requirement, or a change in system condition causes a continuous decrease in power outage. The main sources of reactive energy in synchronizing machines are generators, capacitors, and reactors. When the current field generator is raised, the electromotive power generated will increase. Then, the operating power of the generator is increased to a new level. Therefore, the terminal voltage of the system rises to the required value. AVR control system is a generator that controls the terminal energy of the

synchronization machine and controls the active energy of the system at normal values [G. Singh et al, 2011]. The AVR system consists of four main components, namely:

*Amplifier model:* Amplify the error signal and feed it to the exciter.

$$\frac{V_R(s)}{V_e(s)} = \frac{Ka}{1 + sTa}$$

Where  $Ka$  is amplifier constant and  $Ta$  is time constant

*Exciter model:* to provide a stationary rotating magnetic field to induce the voltage in the armature coil.

$$\frac{V_F(s)}{V_R(s)} = \frac{Ke}{1 + sTe}$$

Where  $Te$  time constant and  $Ke$  is exciter gain

*Generator field model:* convert the mechanical voltage to electrical voltage.

$$\frac{Vt(s)}{V_F(s)} = \frac{Kg}{1 + sTg}$$

Where  $Kg$  generator gain and  $Tg$  is time constant

*Sensor model:* compared the output voltage with a dc setpoint signal to generate the error signal through a bridge rectifier.

$$\frac{Vs(s)}{Vt(s)} = \frac{Kr}{1 + sTr}$$

Where  $Kr$  is the rectifier gain constant and  $Tr$  rectifier time constant.

*Controller:* To improve the dynamic response and to achieve zero steady-state error.

The block diagram of a synchronous generator with automatic voltage regulator is:

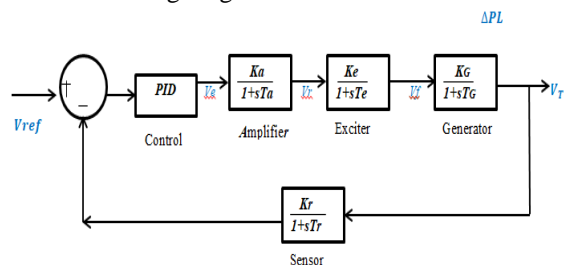

Fig.1: Block diagram of AVR

### 3.2 Automatic Generation Control

The main purpose of the operation and control of the energy system is to maintain a continuous supply of energy with acceptable quality, for all consumers in the system. The system will not be balanced where there is a balance between the demand for energy and the energy produced. Excessive deviation of the

frequency can damage tools, reduce load performance, cause transmission lines to overload and disrupt system protection systems, and ultimately lead to instability of the power system [V. Nath et al 2016]. The main objectives of the AGC are to eliminate frequency variation, effective power, short-term power supply and to distribute productive production [C. Reddy et al, 2017]. A simple diagram of the AGC block of a one-stop power system:

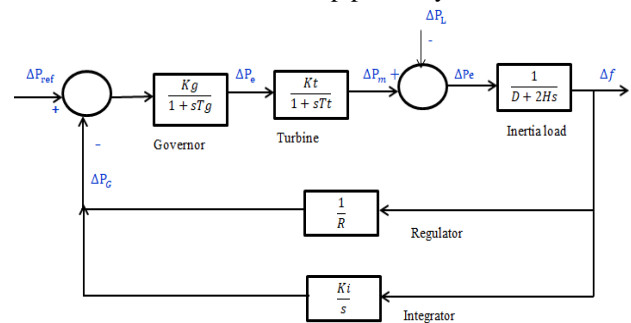

Fig. 2: Block diagram of AGC

### 3.3 Performance improvement controllers

A controller is an existing unit in a control system that produces control signals to reduce the deviation of the required value from the required value to approximately zero or the lowest possible value. Various controls such as the old (correct, flexible) and solid (smart) controls are proposed to improve the flexible performance of the system and to improve the AGC and AVR research parameters.

Classical optimization methods are useful in finding a high-performance solution for continuous and fragmented tasks. These methods have analytics / numbers and enter into statistical measurements. However, their discovery is difficult. Also, the results of this method are site specific. Example: Proportional integral (PI), Proportional integral derivative (PID), Linear quadratic regulator (LQR), etc. Artificial intelligence is modern, robust and multidirectional controls provide faster and more accurate results than the old system. It offers great flexibility to control system flexibility and has a good ability to resist interruptions. Extract difficulty is resolved but the results were still clear with the site. For example: abstract thinking control, genetic algorithm, particle enhancement, simulated simulation, and neural network artificial.

### 3.3.1 Classical Control method

**PID:** a continuous controller that controls the dynamic variables commonly used in industrial control systems to control temperature, flow, pressure, speed, and other process variables. PD controller improves temporary performance and PI control improves control system performance. A block diagram of the PID controller is shown below::

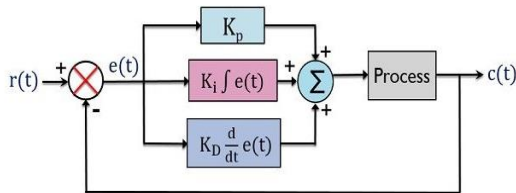

Fig. 3: Equivalent circuit of PID

**LQR:** is a complete control and response control related to the performance of a flexible system at minimal cost (Gregory et al, 1986).

### 3.3.2 Modern Control Method

**Evolutionary Algorithms:** heuristic-based methods of solving problems that cannot be easily solved during polynomial time, such as genetic algorithms and the control of abstract thinking [Devin et al, 2018]. Evolution algorithms are based on the theory of evolution.

**Genetic algorithm:** an evolutionary algorithm based on Darwin's theory of the choice of the most powerful.

**Fuzzy Logic Control:** is used when systems are not very linear and control based on an abstract concept of a mathematical system that analyzes analog input values according to logical variables that take continuous values between 0 and 1.

**Artificial Intelligence:** AI is a computer or neural network component that combines its response to data in much the same way as a human reaction to information (Korikov et al, 2018), as a neural network, particle enhancement. , et al.

**Particle Swarm Optimization:** is a strong stochastic optimization program based on the mobility and intelligence of the masses created by James Kennedy in 1995.

**Artificial Neural Network:** based on the large integration capacity of the sensory system to solve visual problems in the presence of a large amount of sensory data using its same processing power.

SA: based on mechanical process of cooling of molten metals using an anneal.

## 4. Multi-Area Interconnected System

Electrical systems have flexible and sophisticated features and include different control components and many components are linear. These components are connected by tie lines and require frequent control and flow of power [S. Pujan et al 2013]. The main objectives of the multi-site power system are: to reduce the deviation of the power system frequency, to exchange power between fixed distances, and to control the flow of the power of the tie line at a fixed rate [Ali et al, 2016]. [Vijay et al, 2011] introduced the AGC for the four-phase thermal power system and demand side control to reduce the total demand for electrical systems during peak demands to maintain system safety. [K. Parmar et al., 2011] used the LFC dual power system with a DC connector in line with the AC tie line. The LFC and AVR loops proposed in this paper contribute to the efficient operation of the power system by maintaining the frequency and terminal voltage of the corresponding generator at the specified limits. The interconnected system of multiple areas is represented by a ring and a length [V. Nath et al, 2015]. A simplified presentation of the three components of the integrated power system is shown below:

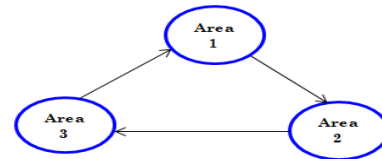

Fig. 4: Representation of Three areas interconnected system  
Tie line power flow from area 1 to area 2 can be written as:

$$P_{tie,12} = \frac{E_1 E_2}{X} \sin(\delta_1 - \delta_2)$$

Tie line power flow from area 1 to area 3 can be written as:

$$P_{tie,13} = \frac{E_1 E_3}{X} \sin(\delta_1 - \delta_3)$$

Tie line power flow from area 3 to area 2 can be written as:

$$P_{tie,32} = \frac{E_3 E_2}{X} \sin(\delta_3 - \delta_2)$$

Where  $\delta$  is a power angle.

Linearizing about an initial operating point we have

$$\Delta P_{tie,ij} = T_{ij} \Delta \delta_{ij} = T_{ij} (\delta_i - \delta_j)$$

Where 
$$T_{ij} = \frac{|E_i||E_j|}{P_{ri}X} \cos((\delta_i - \delta_j)) =$$
  
 Synchronizing coefficient  

$$\Delta P_{tie,ij} = 2\pi T_{ij} (\Delta f_i - \Delta f_j)$$

## 5. Literature Review

Over the past two decades, several research studies on the development of an exciting synchronous generator have been successfully implemented to improve the relaxing features of the energy system over a wide range of workplaces and to improve the flexibility of power systems. [Kundur et al, 1994; Noroozi et.al., 2008; Shahgholian et al, 2010].

Controlling the loading frequency using the old PID controller is used and it is emphasized that the controller performance is better than others. However, if the power system structure has indirect flexibility and components, the operating system is variable and standard controls that require a system model should not be used [R. Narayan et al 2013]. In [S. Moghanlou et al 2006], a robust separation control system is used to control the loading frequency in four-phase power systems to achieve robust stability and better performance.

[Chandrasekhar et al, 2015] presented work on the integrated model of AGC and AVR. PI and PID and Fuzzy control are used on both local systems. Uncomplicated control provides better performance than PI and PID. The ambiguous controller fixes the AGC location control error and AVR Excitation. Therefore, the PID controller is a fixed parameter controller and the power system fluctuates and its configuration changes as its expansion occurs. Therefore, the modified PID parameters of the paramedics cannot provide their best answers. This allows the use of 'human language' to describe problems and their incomprehensible solutions. These are stronger and cheaper than conventional PID controls. [Karna et al, 2019] This paper discussed the control of loading frequency in a dual-connected power system using a PID controller and different enhancement methods. Strong control, Particle swarm upgrades have been shown to be the best development and show good performance over a short period of time with short shooting time and adjusting system frequency. However, the primary backlash does not control the voltage deviation of the system and does not consider cost calculations.

[Reddy et al, 2017] introduced the Automatic Generation Control System Automatically using Functional Disruption Rejection Control to Maintain the frequency of the word within the allowable limits of the thermal power system. The authors conclude that their control system is much better than the previous standard control. However, the authors did not control the terminal voltage and the operating power of the system.

[Sambariya et al, 2016] work on controlling the loading frequency using the incomprehensible Multitask-based Control System. In this work, an obscure concept-based controller is considered the problem of controlling the frequency of the load. But it did not remove the error and the paper did not mention voltage, operating power and tie-line power response from simulation. [Nath et al, 2015] discussed the AGC and AVR analysis of the One Area and the Dual Power System which uses Intelligent Controls Control research and control of frequency and electrical power to a tolerable limit. But the authors did not discuss and did not show the effect of the response of the dual power system. [Sambariya et al, 2015] defined Proper Automatic Generation Control With Automatic Voltage Regulator Using Particle Swarm Optimization of a single local power system. The result shows a statistical error and the correction time for variable responses (frequency and voltage) are detected and detected most effectively using a blurring controller and PID controls based on optimal particle control are considered. However, this paper did not consider the energy system of many areas.

[Narayan et al, 2013] operates an intricate mindset designed to control the frequency of automatic loading of four-component connected power systems. These studies aim to maintain the frequency and power of binding lines at the desired value. The boundary of this paper did not keep system voltage and did not reflect the entire system block diagram. [Dabur et al, 2012] has worked on the Matlab Design and Imitation of AGC and AVR for Multi Area Thermal Power System and Demand Side Management to maintain frequency and power exchange with neighboring systems. The drawback of this paper is that DSM is costly and complex.

Based on that, this review aims to provide explanations of the methods used by previous researchers to obtain the final combination of design

and control parameters to control the frequency and power of the system. In addition, the proposed paper will be a study on the design and control of the AGC and AVR for a multidisciplinary power system using a fluid-powered FLC controller to obtain better operating system features. The results show that the proposed controller has better overshoot, stop time, up time and removes the error values of the solid state for a shorter period of time using dynamic, bidirectional, or modern controls (FLC) rather than standard controls (PID) in the solid state. And temporary conditions. System simulation is done using Matlab / Simulink software.

## 6. Conclusion

In this paper, a detailed review of the AGC design and control and AVR systems for multiple multipurpose systems are introduced to control and maintain the frequency, power, and electrical power of the system. Accordingly, we provide guidance on choosing the appropriate control method based on measuring actual power between generations and demand, balancing effective power between production and load, maintaining the objectives of the combined power flow in FACTS, LFC, AGC, and AVR control frequency, effective power, voltage, and operating power. This paper also introduces comparative features of different types of power system controls and from that AGC is to control and control frequency and power and AVR is to control end-to-end power and operating system of the constant state, stop time and over-shooting) of the system.

## REFERENCE

- [1] K.Karna, G.Veeranna, "Improved Particle Swarm Optimization Algorithm Assisted AGC in interconnected Power System", 2019.
- [2] Reddy & Dr. Krishnarayalu, "Automatic Generation Control of Multi-area Power System using Active Disturbance Rejection Control", 2017.
- [3] Sambariya & V. Nath, "Load Frequency Control Using Fuzzy Logic Based Controller for Multi-area Power System", 2016.
- [4] K. Sambariya & V. Nath, "Optimal Control of Automatic Generation with Automatic Voltage Regulator Using Particle Swarm Optimization", 2015.
- [5] V.Nath & D. Sambariya, "Analysis of AGC and AVR for Single Area and Double Area Power System Using Fuzzy Logic Control", 2015.
- [6] N.Tanwani, P. Memon et al., "Simulation Techniques of Electrical Power System Stability Studies Utilizing Matlab/Simulink", 2014.
- [7] R.Narayan, S.Jaiswal et al., "Fuzzy Logic Based Automatic Load Frequency Control of Multi-Area Power Systems", 2013.
- [8] P.Dabur, N.Yadav, et al., "Matlab Design and Simulation of AGC and AVR for Single Area Power System with Fuzzy Logic Control", 2012.
- [9] P. Dabur, N. Yadav & V.Kumar, "Matlab Design and Simulation of AGC and AVR for Multi-Area Power System and Demand Side Management", 2011.
- [10] Singh & R.Bala, "Automatic Generation & Voltage Control of Interconnected Thermal Power System Including Load Scheduling Strategy", 2011.
- [11] T. Win, and M. Aung, "Simulation of Synchronous Machine in Stability Study for Power System," World Academy of Science, Engineering and Technology, 2008.
- [12] Naresh K and Tanwani, "Analysis and Simulation Techniques of Electrical Power System Stability Studies", 2013.
- [13] R. Narne, P. Jose. P. Therattil, "Transient Stability Enhancement of SMIB System using PSS and TCSC-Based Controllers," IEEE PEDS, 2011.
- [14] Khothar Suhail, "Feedforward Neural Network-based Power System Stabilizer for excitation Control System," M.E. Thesis, Department of Electrical Engineering, 2011.
- [15] Aslam P. Memon, "Design of FFNN AVR for Enhancement of Power System Stability Using Matlab/Simulink," Mehran University, 2012.
- [16] Asma Aziz, Amanullah, et al, "Automatic Generation Control of Multigeneration Power System," Journal of Power and Energy Engineering, 2014.
- [17] Y. Arya, P. Dahiya, et al, "AGC performance amelioration in multi-area interconnected thermal and thermal-hydro-gas power systems using a novel controller", ELSEVIER, 2021.
- [18] Deepesh Sharma, "Automatic generation control of multi-source interconnected power system using adaptive neuro-fuzzy inference system", IJEST, 2020.
- [19] K. Ullah, A. Basit, et al, "Automatic Generation Control Strategies in Conventional and Modern Power Systems: A Comprehensive Overview", MDPI/energy, 2021.
- [20] G. Singh, J. Kaur, "Load Frequency and Voltage Control of Two Area Interconnected Power System using PID Controller", IJERT, 2016.
- [21] Deepesh Sharma, "Load Frequency Control: A Literature Review", IJSTR, 2020.
- [22] Kayalvizhi, S., Kumar, D.M.V. (2017). Load frequency control of an isolated microgrid using fuzzy adaptive model predictive control. IEEE Access, 2017.
- [23] H. Espitia, I. Machon, "Optimization of a Fuzzy Automatic Voltage Controller Using Real-Time Recurrent learning", MDPI/energy, 2021.
- [24] Z. Obaid, M. Cipcigan, et al, "Frequency control of future power systems: reviewing and evaluating challenges and new control methods", Springer, 2019.
- [25] S. Egoigwe, C. Chukwudi, et al, "Application of a Fuzzy Logic Controller for Hydropower Generator Speed Regulation", EJERS, 2019.



### ***BIOGRAPHIES***

**Abdulkerim Ali** was born in Bahir Dar, Ethiopia on Sep. 12/1991 G.C.



He was learned from primary to preparatory school in Bahirdar. He graduated from Adama Science and Technology University with B.Sc. in Electrical Engineering specializing in Control System Engineering in 2013G.C and finished a Master's degree in June, 2016G.C with Electrical Engineering specializing in Power system Engineering. And now studied PhD. from Bahirdar Institute of Technology, Ethiopia by Power System Engineering.

My special fields of interest include teaching modern control systems, machines, and other related courses.

IJSER